

## LINK FITTINGS

### 1. Ball Eye (Type Q & QP)

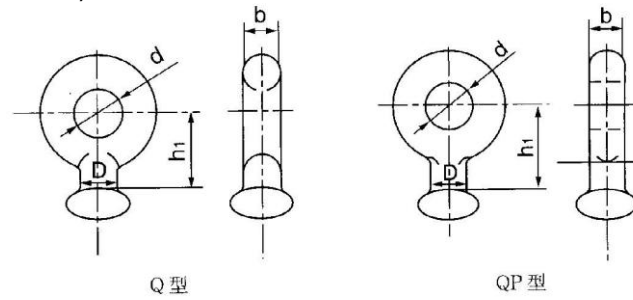

Cat No	Suitable Insulator	Ball IEC code	Dimensions(mm)				Rated Failure Load (KN)	Weight (Kg)
			A	B	C	D		
Q-7	XP-7	16mmA.B.	17	22	16	50	70	0.3
QP-7	XP-7	16mmA.B.	17	20	16	50	70	0.3
QP-10	XP-10	16mmA.B.	17	20	16	50	100	0.3
QP-12	XP-12	16mm	17	20	16	50	120	0.3
QP-16	XP-16	20mm	24	26	20	60	160	0.5
QP-21D	XP-21	20mm	21	29	20	70	210	1.0
QP-20	XP-20	24mm	25	30	24	80	200	1.0
QP-30	XP-30	24mm	25	39	30	80	300	1.1

Made of hot-dip galvanized drop forged steel .

### 2. Ball Eye (Type QH)

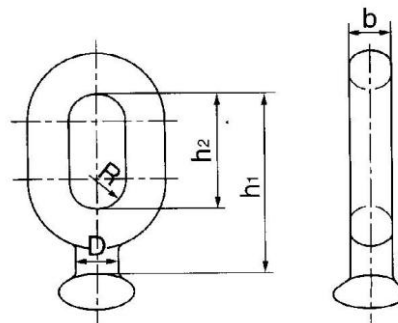

Cat No	Suitable Insulator	Dimensions(mm)					Rated Failure Load (KN)	Weight (Kg)
		h1	h2	R	D	b		
QH-7	XP-7	114	57	11	17	16	70	0.6
QH-12	XP-12	120	63	11	17	16	120	0.7
QH-16	XP-16	130	70	13	26	20	160	1.0
QH-7A	XP-7	90	52	11	17	16	70	0.5

Made of hot-dip galvanized drop forged steel .

### 3. Ball Eye (Perpendicular type, horn holder type)

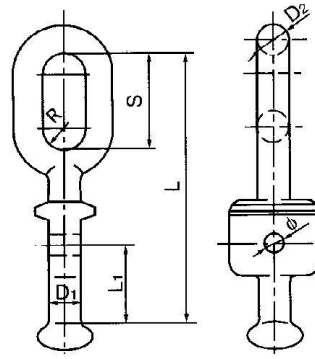

Cat No	Suitable Insulator	Dimensions(mm)							Ball IEC code	Rated Failure Load (KN)	Weight (Kg)
		L	L1	D1	D2	S	R	$\phi$			
Q-7N	XP-7	165	48	16	16	56	12.5	14	16mmA.B	70	1.2
Q-12N	XP-12	165	48	16	16	56	12.5	14	16mmA.B	120	1.5
Q-16N	XP-16	176	48	20	20	80	15	14	20mm	160	1.8

Made of hot-dip galvanized drop forged steel .

### 4. Ball Eye (Parallel type, horn holder type)

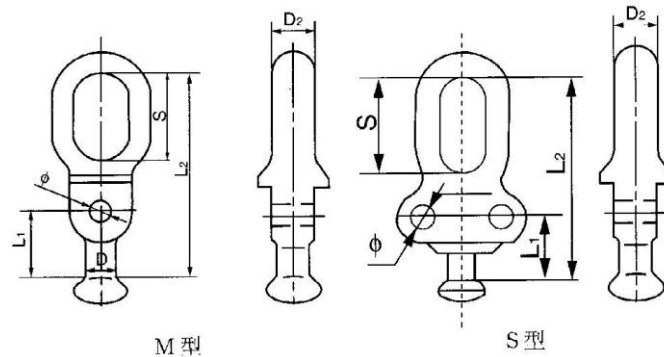

Cat No	Suitable Insulator	Dimensions(mm)						Ball IEC code	Rated Failure Load (KN)	Weight (Kg)
		L1	L2	S	D	D2	$\phi$			
Q-7M	XP-7	42	142	60	16	16	14	16mmA.B	70	1.0
Q-12M	XP-12	48	145	60	18	18	14	16mmA.B	120	1.3
Q-16M	XP-16	48	160	80	20	20	14	20mm	160	1.5
Q-12S	XP-12	48	134	60	18	18	14	16mmA.B	120	1.3

Made of hot-dip galvanized drop forged steel .

## 5. Ball Eye (Horn holder type)

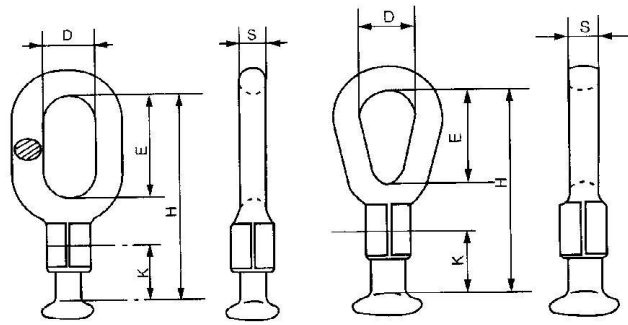

Fig 1

Fig 2

Cat No	Fig. No.	Dimensions(mm)					Ball IEC code	Rated Failure Load (KN)	Weight (Kg)
		D	E	H	K	S			
Q-7CH	1	30	50	120	39	16	16mmA.B	70	0.50
Q-12CH	1	34	70	143	39	18	16mmA.B	120	0.75
Q-16CH	2	34	70	146	42	20	20mm	160	1.10
Q-21CH	2	34	70	146	42	20	20mm	210	1.10

Made of hot-dip galvanized drop forged steel .

## 6. Ball Eye (Horn holder type)

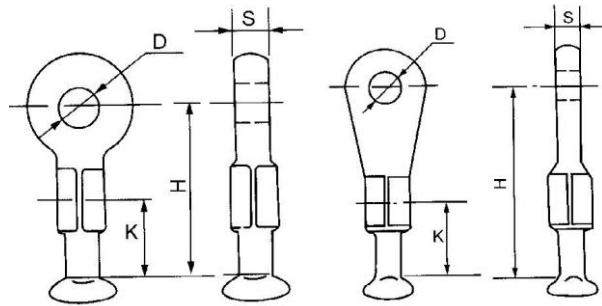

Fig 1

Fig 2

Cat No	Fig. No.	Dimensions(mm)				Ball IEC code	Rated Failure Load (KN)	Weight (Kg)
		D	H	K	K			
Q-7PH	1	18	82	39	16	16mmA.B	70	0.6
Q-10PH	1	20	82	39	16	16mmA.B	100	0.6
Q-12PH	1	22	87	39	16	16mmA.B	120	0.6
Q-16PH	2	26	146	42	20	20mm	160	0.9
Q-21PH	2	26	169	42	22	20mm	210	1.2

Made of hot-dip galvanized drop forged steel .

## 7. Ball Eye (Horn holder type)

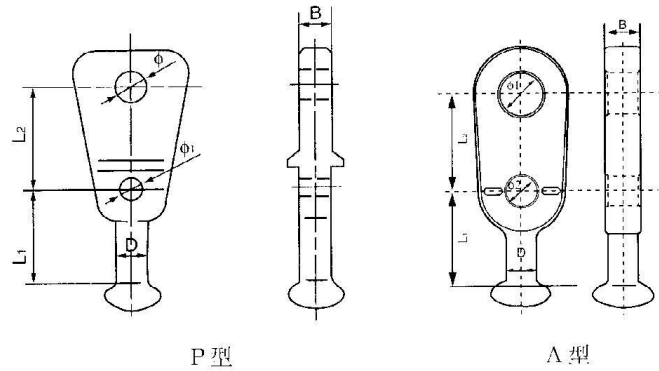

Cat No	Suitable Insulator	Dimensions(mm)						Ball IEC code	Rated Failure Load (KN)	Weight (Kg)
		L1	L2	D	$\phi$	$\phi_1$	B			
Q-7P	XP-7	57	60	17	20	14	16	16mmA.B	70	0.8
Q-12P	XP-12	57	65	17	24	14	18	16mmA.B	120	0.85
Q-7A	XP-7	48	56	17	18	14	16	16mmA.B	70	0.5
Q-12A	XP-12	48	56	17	20.5	17.5	19	16mmA.B	133	0.65

Made of hot-dip galvanized drop forged steel .

## 8.U type Ball Eye

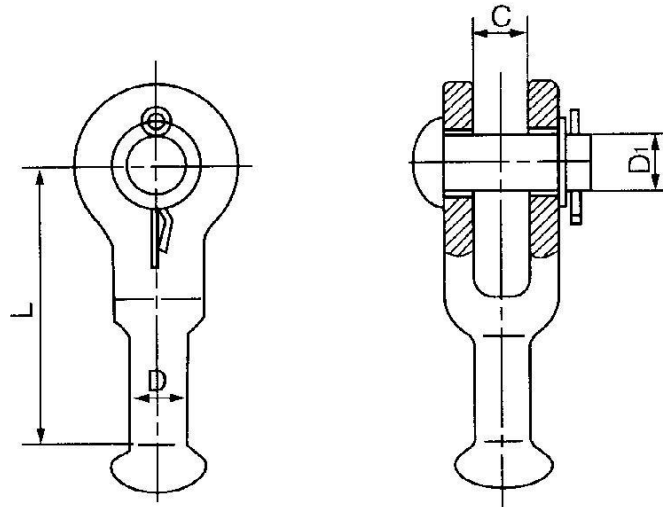

Cat No	Suitable Insulator	Dimensions(mm)				Ball IEC code	Rated Failure Load (KN)	Weight (Kg)
		C	D1	D	L			
Q-7U	XP-7	18	16	17	89	16mmA.B	70	0.9
Q-12U	XP-12	22	22	17	95	16mmA.B	120	1.0
Q-16U	XP-16	24	24	20	80	20mm	160	1.0

The body is made of hot-dip galvanized drop forged steel. Cotter-pin is made of stainless steel.

**9. Ball Clevis**

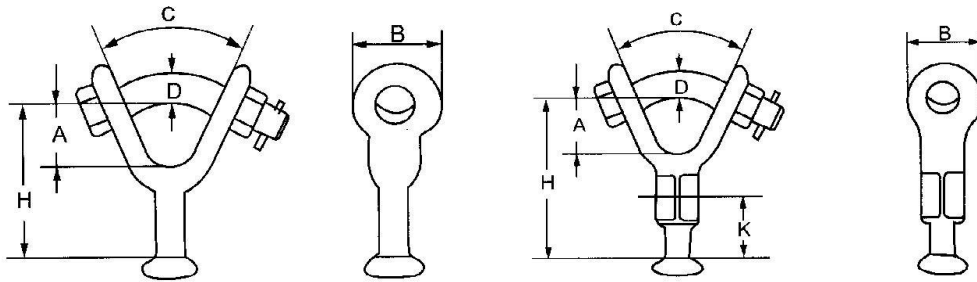

Fig 1

Fig 2

Cat No	Fig. No.	Dimensions(mm)						Ball IEC code	U.T.S (KN)	Weight (Kg)
		A	B	C	D	H	K			
QB-7Y	1	38	40	45°	16	75	-	16mmA.B	70	0.55
QB-10Y	1	40	42	45°	18	75	-	16mmA.B	100	0.78
QB-12Y	1	40	44	45°	18	82	-	16mmA.B	120	0.80
QB-7YH	2	38	40	45°	16	105	39	16mmA.B	70	0.72
QB-10YH	2	40	42	45°	18	112	42	16mmA.B	100	0.98
QB-12YH	2	40	44	45°	18	112	42	16mmA.B	120	1.20

The body is made of forged drop steel, Balls sizes are in accordance with IEC,GB or ANSI standards.

**10. Ball Clevis (Horn holder type)**

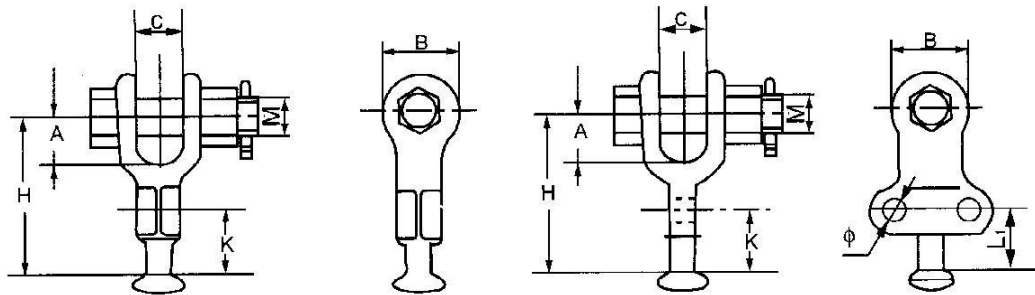

Cat No	Dimensions(mm)						Ball IEC code	U.T.S (KN)	Weight (Kg)
	A	B	C	M	H	K			
Q-7YH	38	40	18	16	107	39	16mmA.B	70	1.55
Q-10YH	40	42	22	18	112	39	16mmA.B	100	1.78
Q-12YH	40	44	22	18	112	39	16mmA.B	120	1.80
Q-7UH	38	44	18	16	110	39	16mm	70	1.25

The body is made of forged drop steel, Balls sizes are in accordance with IEC,GB or ANSI standards.

## 11.Socket Tongue

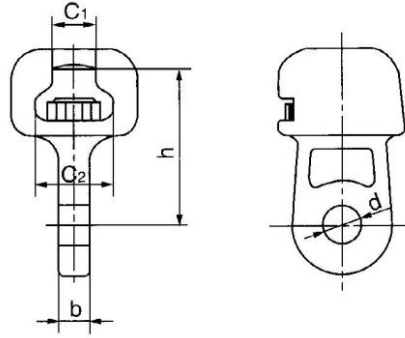

Cat No	Suitable Insulator	Dimensions(mm)					Socket IEC code	Rated Failure Load (KN)	Weight (Kg)
		C1	C2	h	d	b			
W-7A	XP-7 XP-4.5	19.2	34.5	70	20	16	16mmA.B	70	0.8
W-7B	XP-7 X-4.5	19.2	34.5	115	20	16	16mmA.B	70	0.9
W1-10	XP-10	19.2	34.5	85	20	18	16mmA.B	100	1.0
W1-12	XP-12	19.2	34.5	85	20	20	16mmA.B	120	1.2

The body is made of malleable iron, hot-dip galvanized. Security clip is made of bronze or stainless steel.

## 12. Socket Eye (Type R)

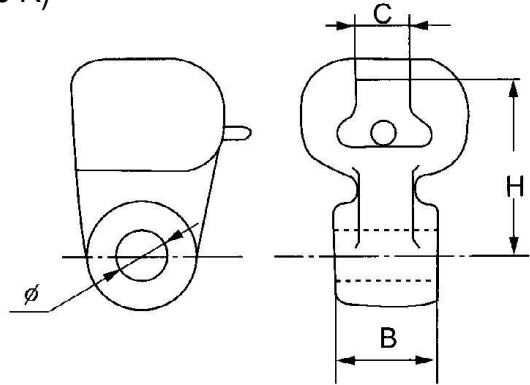

Cat No	Dimensions(mm)				Socket IEC code	Rated Failure Load (KN)	Weight (Kg)
	B	C	H	φ			
W-7AG	24	19.2	70	20	16mmB	70	1
W-7BG	26	19.2	115	20	16mmB	70	1.1
W-10AG	34	19.2	85	20	16mmB	100	1.2
W-12AG	38	19.2	65	20	16mmA	120	1.3
W-12BG	54	19.2	115	20	16mmA	120	1.5
W-12CG	61	19.2	65	20	16mmA	120	1.5

The body is made of malleable iron, hot-dip galvanized. Security clip is made of bronze or stainless steel.

## 13.Socket Eye (Horn holder type)

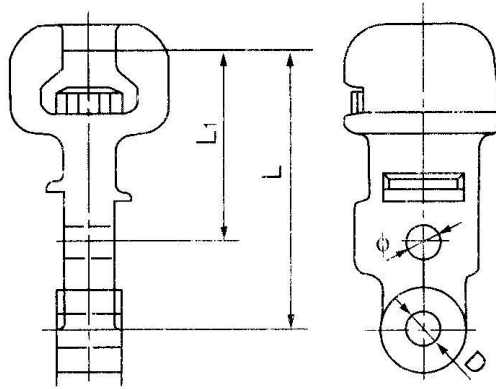

Cat No	Suitable Insulator	Dimensions(mm)					Socket IEC code	Rated Failure Load (KN)	Weight (Kg)
		L	L1	B	D	Φ			
W1-7K	XP-7 XP-4.5	120	70	20	18	14	16mm	70	1.0
W1-12K	XP-12	120	70	22	24	14	16mm	120	1.3

W1-7K socket eye is made of malleable iron, W1-12K socket eye is made of casting steel, the security clips are made of bronze or stainless steel. All ferrous parts are hot-dip galvanized

## 14. Socket Eye (Horn holder type)

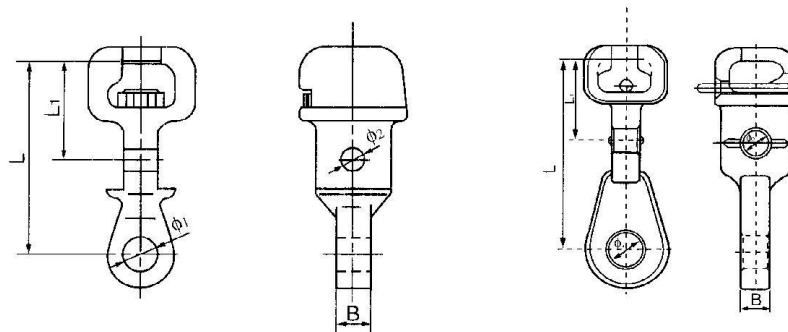

R 型

A 型

Cat No	Suitable Insulator	Dimensions(mm)					Socket IEC code	Rated Failure Load (KN)	Weight (Kg)
		L	L1	Φ1	Φ2	B			
W1-7R	XP-7 XP-4.5	120	70	18	14	20	16mm	70	1.0
W1-12R	XP-12	120	70	22	14	22	16mm	120	1.3
W1-7A	XP-7	126	55	18	14	16	16mm	70	1.48
W1-12A	XP-12	126	55	21.5	17.5	19	16mm	120	1.48

W1-7R/A socket eye is made of malleable iron, W1-12R/A socket eye is made of casting steel, the security clips are made of bronze or stainless steel. All ferrous parts are hot-dip galvanized.

## 15. Socket Clevis (Type WS)

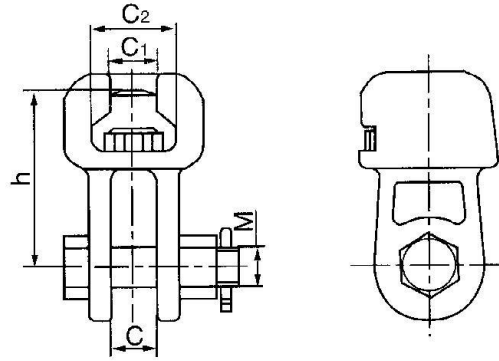

Cat No	Suitable Insulator	Dimensions(mm)					Socket IEC code	Rated Failure Load (KN)	Weight (Kg)
		C	C1	C2	M	h			
WS-7	XP-7	18	19.2	34.5	16	70	16mm	70	1.0
WS-10	XP-10	20	19.2	34.5	18	85	16mm	100	1.2
WS-16	XP-16	26	23.0	42.5	24	95	20mm	160	2.6
WS-20	XP-20	30	27.5	51.0	27	100	24mm	200	4.5
W2-21D	XP-21	30	23.0	42.5	27	100	20mm	210	4.3
WS-30	XP-30	36	27.5	51.0	36	110	24mm	300	5.7

Type WS-7 and WS-10 socket clevis are made of malleable iron, other type of socket clevis are made of casting steel, the security clips are made of bronze or stainless steel., cotter-pins are made of stainless steel, other parts are steel. All ferrous parts are hot-dip galvanized

## 16.Socket Clevis (Elongated type WS)

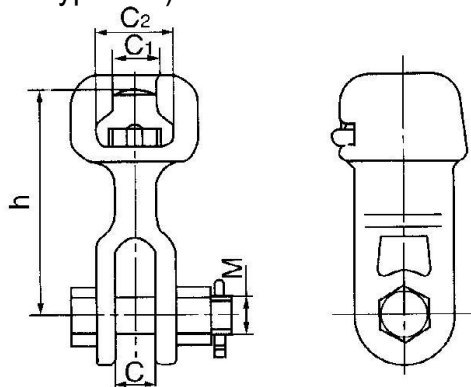

Cat No	Dimensions(mm)					Socket IEC code	Rated Failure Load (KN)	Weight (Kg)
	C	H	M	C1	C2			
WS-7H	20	163	16	19.2	34.5	16mm	70	1.50
WS-12H	20	163	18	19.2	34.5	16mm	120	2.1
WS-16H	22	165	22	23.0	42.5	20mm	160	2.8
WS-20H	22	188	22	23.0	42.5	24mm	200	4.7

The security clips are made of bronze or stainless steel. The cotter -pins are made of stainless steel, other parts are hot-dip galvanized steel.



## 17. Socket Thimble

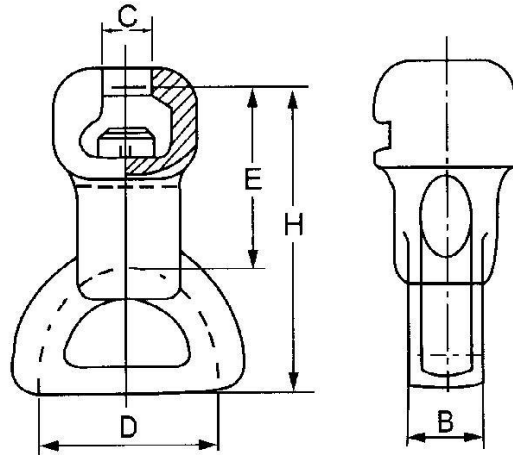

Cat No	Dimensions(mm)					Couple code IEC120	Weight (Kg)
	B	C	D	E	H		
WX-7A	28	19.2	50	65	110	16mm	1.30
WX-7B	30	19.2	70	65	110	16mm	1.35

The body is made of malleable iron hot-dip galvanized W-clip pin is made of bronze or stainless steel.

## 18.Socket Clevis (Y-type)

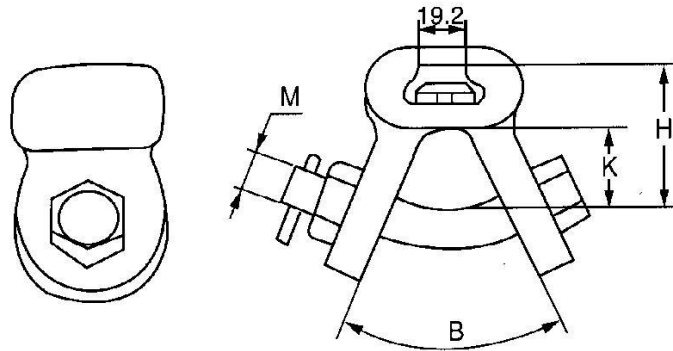

Cat No	Dimensions(mm)				Couple code IEC120	U.T.S (KN)	Weight (Kg)
	B	H	M	K			
WS-7Y	45°	73	20	38	16mm	70	1.51
WS-10Y	45°	86	22	51	16mm	100	2.60
WS-12Y	45°	86	24	51	16mm	120	2.60

The body is made of malleable iron or steel. Hot-dip galvanized, W-clip or R-split pin is made of stainless steel or bronze. All ferrous parts are hot-dip galvanized.

## 19. Anchor Shackle

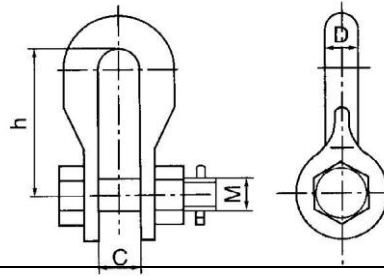

Cat No	Dimensions(mm)				Rated Failure Load (KN)	Weight (Kg)
	C	M	D	h		
U-7	20	16	16	60	70	0.5
U-7B	20	16	16	80	70	0.6
U-10	22	18	18	70	100	0.6
U-10B	22	18	18	85	100	0.7
U-12	24	22	20	80	120	1.0
U-16	26	24	22	90	160	1.5
U-16T	28	24	22	90	160	1.5
U-20	30	27	24	100	200	2.3
U-20B	30	27	24	115	200	2.4
U-25	34	30	26	110	250	2.8
U-30	38	36	30	130	300	3.7
U-50	44	42	36	150	500	7.0

The cotter pin is made of stainless steel, other parts are made of hot-dip galvanized drop forged steel

## 20. Anchor Shackle

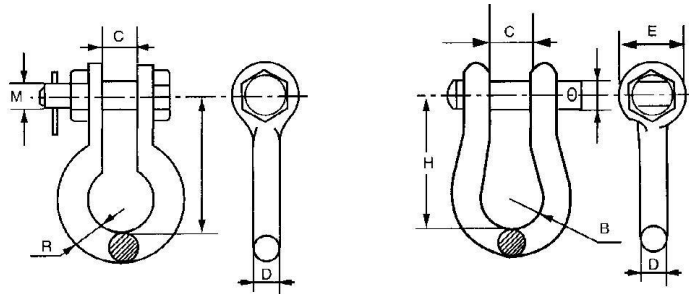

A 型 (Cat. No. ending with A)

R 型 (Cat. No. ending with R)

Cat No	Dimensions(mm)						U.T.S (KN)	Weight (Kg)
	C	D	E	H	M	R		
U-7A	19	16	38	76	16	11	70	0.65
U-12A	22	18	40	72	18	18	120	0.72
U-16A	26	20	44	89	20	19	160	0.98
U-22A	26	22	51	89	22	19	220	1.45
U-7R	20	16	70	16	16	19	70	0.5
U-12R	22	20	80	20	20	19	120	1.0

The cotter pin is made of stainless steel, other parts are made of hot-dip galvanized drop forged steel

## 21. Twisted Shackle

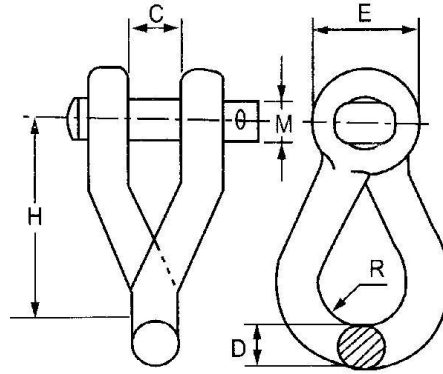

Cat No	Dimensions(mm)						U.T.S (KN)	Weight (Kg)
	C	D	E	H	M	R		
UN-7	18	16	34	76	16	16	70	0.6
UN-10	18	18	38	76	16	16	100	0.7
UN-12	19	18	38	76	16	16	120	0.70
UN-16	22	20	44	102	20	19	160	1.05

The cotter pin is made of stainless steel, other parts are made of hot-dip galvanized drop forged steel

## 22. Vee Shackle

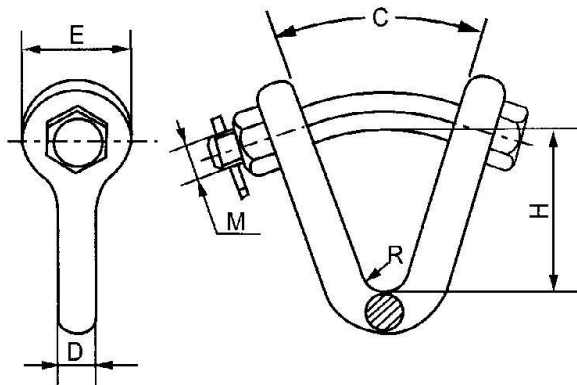

Cat No	Dimensions(mm)						U.T.S (KN)	Weight (Kg)
	C	D	E	H	M	R		
V-7	35°	16	38	70	18	10	70	0.80
V-10	35°	18	40	70	20	10	100	0.85
V-12	35°	24	44	90	22	13	120	0.98
V-16	35°	24	48	90	24	13	160	1.10
V-20	35°	24	54	100	27	19	200	1.45

The cotter pin is made of stainless steel, the other parts are made of hot-dip galvanized drop forged steel.

## 23. Twisted Strap

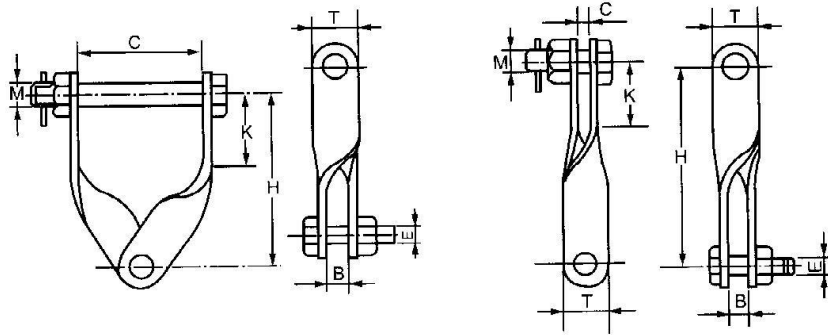

Cat No	A 型							B 型	U.T.S (KN)	Weight (Kg)
	Dimensions(mm)									
	B	C	M	E	H	K	T			
VB-7A	16	102	16	16	143	48	38		70	1.42
VB-7B	16	13	16	16	165	51	38		70	1.25
VB-12A	20	110	22	22	150	50	60		120	2.5
VB-12B	20	20	22	22	165	51	60		120	2.1

The cotter pin is made of stainless steel, other parts are made of hot-dip galvanized drop forged steel

## 24. Hinge to Tower

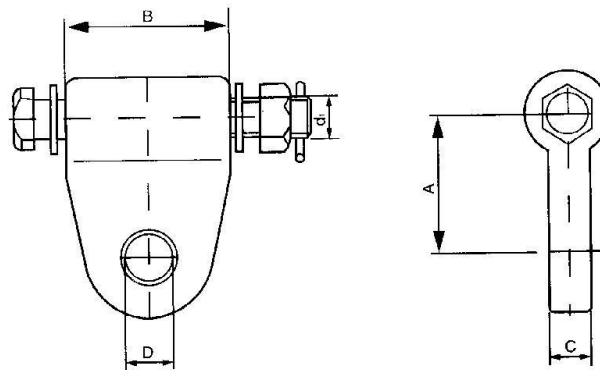

Cat No	Dimensions(mm)					Rated Failure Load (KN)	Weight (Kg)
	B	A	C	D	d1		
JLB-12A	55	75	22	21.5	20	120	0.92
JLB-12B	55	75	22	17.5	20	120	0.95
JLB-16	70	80	22	21.5	20	160	1.88
JLB-12C	70	85	16	17.5	20	120	1.30
JLB-12D	70	85	22	17.5	20	120	1.90
JLB-32A	90	80	22	23.5	24	320	2.30
JLB-32B	110	80	22	23.5	24	320	2.90
JLB-32C	110	75	22	28.5	27	320	3.16

The cotter pin is made of stainless steel, the other parts are made of hot-dip galvanized drop forged steel.

## 25. Clevis Eye

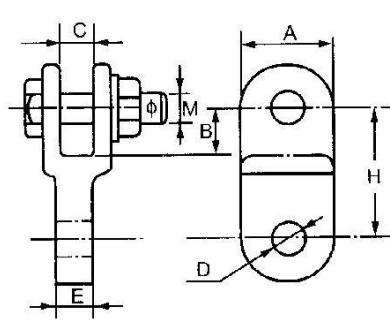

Fig 1

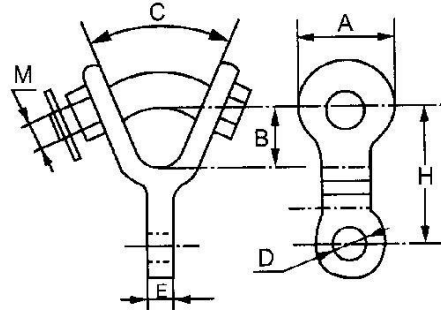
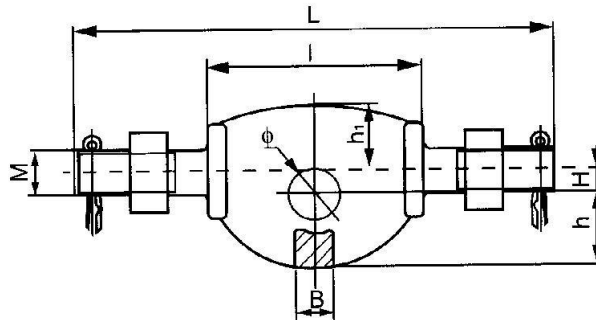

Fig 2

Cat No	Fig. No.	Dimensions(mm)							U.T.S (KN)	Weight (Kg)
		A	B	C	D	E	H	M		
PG-7	1	44	28	19	18	16	65	16	70	0.80
PG-10	1	44	30	22	22	20	70	18	100	0.98
PG-12	1	52	38	24	24	20	80	20	120	1.10
PG-16	1	60	54	26	26	24	90	22	160	0.70
PG-7Y	2	44	38	45°	18	16	80	20	70	0.89
PG-10Y	2	44	38	45°	22	18	90	22	100	0.98
PG-12Y	2	44	38	45°	24	20	92	24	120	1.31
PG-16Y	2	44	38	45°	26	24	106	24	160	1.40

The cotter pin is made of stainless steel, other parts are made of hot-dip galvanized drop forged steel

## 26. Twisted Strap



Cat No	Dimensions(mm)								U.T.S (KN)	Weight (Kg)
	L	I	Φ	M	H	B	h	h1		
GD-12S	250	112	24	22	12	16	40	35	120	1.7
GD-21S	250	112	26	24	12	20	40	35	210	2.1
GD-32S	258	112	33	30	12	28	40	36	320	3.6
GD-42S	278	130	39	36	12	32	45	36	420	4.2
GD-50S	278	130	39	36	12	32	48	50	500	4.6

The cotter pin is made of stainless steel, the other parts are made of hot-dip galvanized drop forged steel.

## 27. Eye Chain Link (90° shifted)

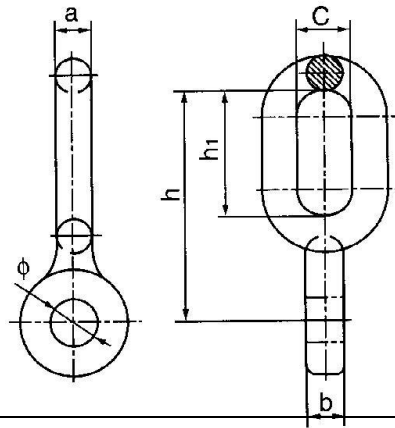

Cat No	Dimensions(mm)						Rated Failure Load (KN)	Weight (Kg)
	a	b	c	Φ	h1	h		
ZH-7	16	16	24	20	57	95	70	0.5
ZH-10	16	16	24	20	57	95	100	0.5

Made of hot-dip galvanized drop forged steel

## 28. Chain Link (Forged type)

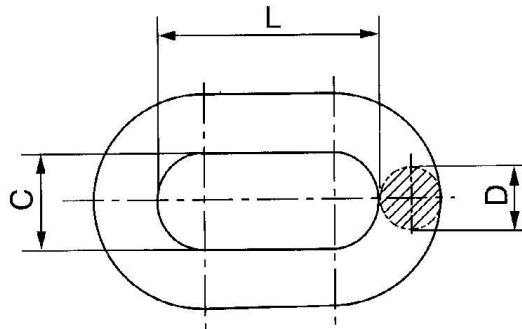

Cat No	Dimensions(mm)			Rated Failure Load (KN)	Weight (Kg)
	C	D	L		
PH-7.1	20	16	80	70	0.4
PH-10.1	22	18	100	100	0.6
PH-12.1	24	20	120	120	0.9
PH-16.1	26	22	140	160	1.5
PH-20.1	30	24	160	200	1.6
PH-25.1	34	26	160	250	2.0
PH-30.1	38	30	180	300	3.0

Made of drop forged steel, hot-dip galvanized.

## 29. Clevis (Type Z)

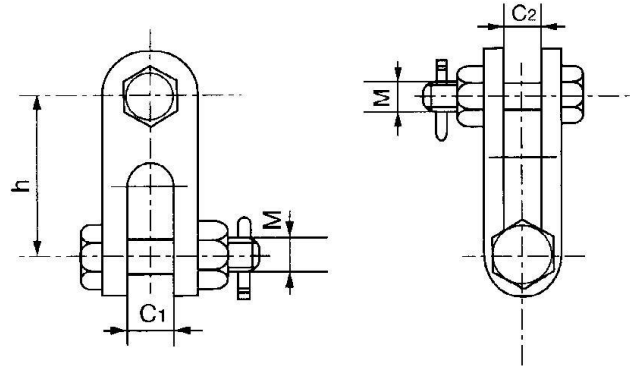

Cat No	Dimensions(mm)				Rated Failure Load (KN)	Weight (Kg)
	C1	C2	M	h		
Z-7	18	18	16	60	70	0.6
Z-7B	20	18	16	80	70	0.7
Z-10	20	20	18	70	100	0.8
Z-10B	20	20	18	80	100	0.9
Z-12	24	24	22	80	120	1.3
Z-12B	24	24	22	100	120	1.32
Z-16	26	26	24	90	160	2.5
Z-16B	26	26	24	100	160	2.55
Z-16B1	26	26	24	140	160	3.2
Z-16B2	26	26	24	170	160	3.8
Z-20	30	30	27	120	200	3.5
Z-25	34	34	30	110	250	3.8

The cotter pin is made of stainless steel, the other parts are made of hot-dip galvanized steel.

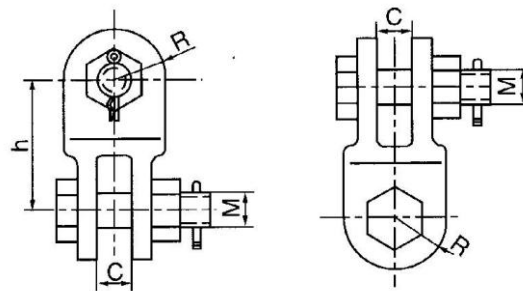

Cat No	Dimensions(mm)				Rated Failure Load (KN)	Weight (Kg)
	C	R	M	h		
Z1-25	34	40	30	100	250	2.8
Z1-30	38	46	36	135	300	5.4
Z1-40	42	50	36	150	400	8.6
Z1-60	50	62	48	180	600	19.6

The cotter pin is made of stainless steel, the other parts are made of hot-dip galvanized steel.

## 30.Clevis (Type PS)

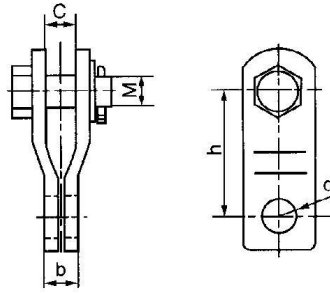

Cat No	Dimensions(mm)					Rated Failure Load (KN)	Weight (Kg)
	C	b	M	d	h		
PS-7	18	16	16	20	90	70	0.6
PS-12	22	16	22	24	120	120	3.2
PS-20	26	20	27	29	140	200	3.5
PS-30	38	32	36	39	150	300	5.9

The cotter pin is made of stainless steel, the other parts are made of hot-dip galvanized steel.

## 31.Clevis Hinge (Type UB)

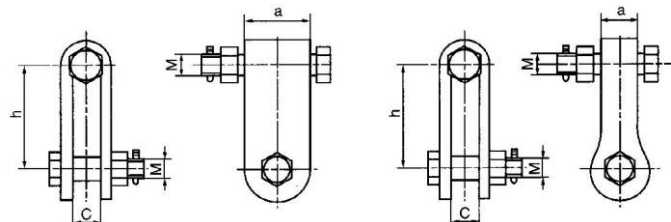

Cat No	Dimensions(mm)				Fig. No.	Rated Failure Load (KN)	Weight (Kg)
	C	M	h	a			
UB-7	18	16	70	45	1	70	0.8
UB-10	20	18	80	45		100	1.1
UB-12	24	22	100	60		120	2.8
UB-16	26	24	100	60		160	2.9
UB-16G	24	20	90	48		160	2.9
UB-20	30	27	120	72		200	3.6
UB6-1	20	16	65	30	2	60	0.8
UB-7T	20	16	60	35		70	0.8
UB9-1	26	18	75	40		90	0.9
UB-10T	22	18	70	35		100	1.0
UB-12T	24	22	80	40		120	2.1
UB-16T	26	24	110	40		160	2.5
UB-20T	30	27	120	60		200	3.0
UB-25T	36	30	140	60		250	3.0
UB-30T	36	36	150	60		300	3.7

The cotter pin is made of stainless steel, the other parts are made of hot-dip galvanized steel.



## 32.Extension Link

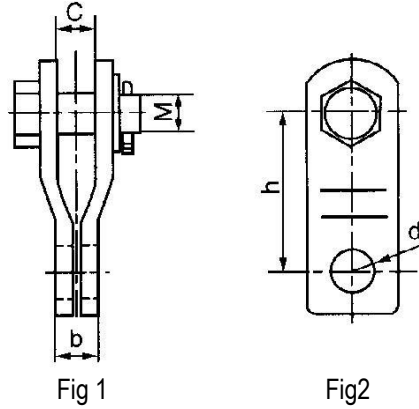

Cat No	Fig. No.	Dimensions(mm)				U.T.S (KN)	Weight (Kg)
		A	B	L	M		
YB-7A	1	40	18	200	16	70	1.50
YB-10A	1	40	18	200	18	100	1.62
YB-12A	1	50	20	200	22	120	2.00
YB-16A	1	50	20	550	24	160	4.60
YB-7B	2	50	18	300	16	70	1.58
YB-10B	2	40	18	400	18	100	2.63
YB-12B	2	50	20	450	22	120	2.80

The cotter pins are made of stainless steel or bronze, others are made of hot-dip galvanized steel

## 33.Extension Rod

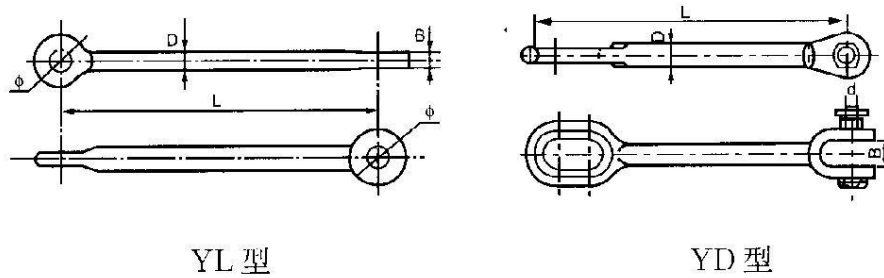

Cat No	Dimensions(mm)				U.T.S (KN)	Weight (Kg)
	Φ	D	B	L		
YL-1040	18	20	16	400	100	0.9
YL-1243	22	24	18	430	120	1.3
YL-1640	30	26	20	400	160	2.75
YL-1040	16	20	18	250	100	0.9
YL-1243	18	20	20	250	120	1.3
YL-1640	22	26	26	430	160	2.75

Made of hot-dip galvanized drop forged steel.

## 34. U-Bolt

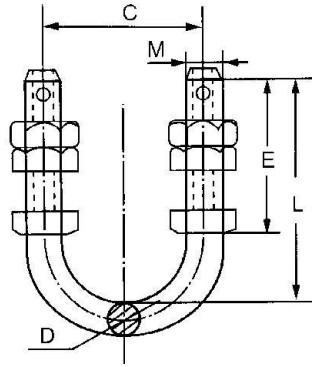

Cat No	Dimensions(mm)					U.T.S (KN)	Weight (Kg)
	C	D	E	L	M		
U-1240	40	12	45	80	12	35	0.38
U-1440	40	14	60	90	14	35	0.42
U-1470	70	14	70	120	14	40	0.46
U-1670	70	16	65	130	16	50	0.66
U-1870	70	18	80	130	18	60	0.86
U-1880	80	18	60	130	18	60	0.88
U-1890	90	18	60	140	18	60	0.90
U-2070	70	20	90	130	20	70	1.20
U-2080	80	20	70	140	20	70	1.70
U-2090	90	20	90	150	20	70	1.28
U-2280	80	22	90	150	22	100	1.0
U-2290	90	22	100	160	22	100	1.34

The cotter pin is made of stainless steel, other parts are made of hot-dip galvanized steel

## 35. U-Bolt Enhanced

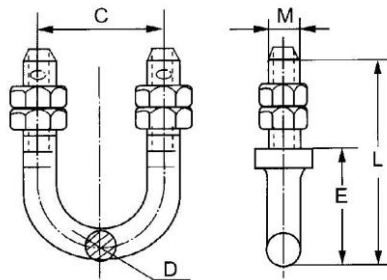

Cat No	Dimensions(mm)					U.T.S (KN)	Weight (Kg)
	C	D	E	L	M		
UJ-1880	80	18	39	130	18	60	0.88
UJ-2080	80	20	43	140	20	70	1.08
UJ-2280	80	22	45	150	22	100	1.28

The cotter pin is made of stainless steel or bronze, other parts are made of hot-dip galvanized steel

## 36. Adjusting Plate (Type PT)

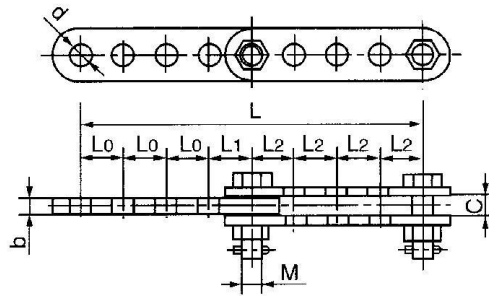

Cat No	Dimensions(mm)								Rated Failure Load (KN)	Weight (Kg)
	L0	L1	L2	M	d	b	c	L		
PT-7	45	30	45	16	18	16	18	225-345	70	2.18
PT-10	50	40	50	18	20	16	20	225-390	100	3.12
PT-12	60	45	60	22	24	16	34	300-465	120	5.27
PT-16	65	50	60	24	26	18	26	325-505	160	7.03
PT-20	70	60	70	27	29	24	30	350-550	200	10.05
PT-30	80	70	80	36	39	32	38	400-630	300	14.0
PT-50	160	80	100	42	45	38	40	470-1280	500	24.6
PT-60	180	90	100	48	51	42	44	820-1390	600	31.6

Made of hot-dip galvanized steel.

## 37. Sag Adjuster Plate (Type DB)

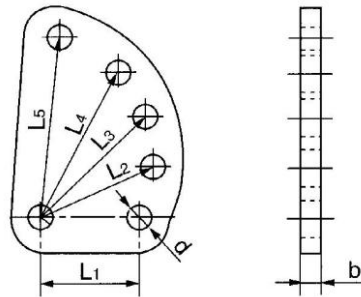

Cat No	Dimensions(mm)							Rated Failure Load (KN)	Weight (Kg)
	d	b	L1	L2	L3	L4	L5		
DB-7	18	16	70	95	120	145	170	70	1.7
DB-10	20	16	80	110	140	170	200	100	2.7
DB-12	24	16	100	135	170	205	240	120	4.0
DB-16	26	18	110	125	140	155	170	160	4.1
DB-20	30	26	120	135	150	165	180	200	7.4
DB-30	39	32	120	140	160	180	200	300	12.5
DB-50	45	38	140	185	230	275	320	500	29.0
DB-60	51	42	135	160	185	210	235	600	31.6

Made of hot-dip galvanized steel.

## 38. Yoke Plate (Type L)

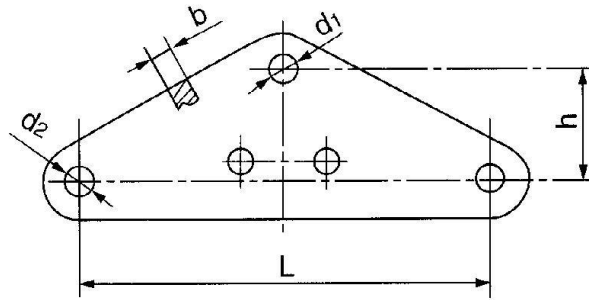

Cat No	Dimensions(mm)					Rated Failure Load (KN)	Weight (Kg)
	b	h	d1	d2	L		
L-1040	16	70	20	18	400	100	4.5
L-1240	16	70	24	18	400	120	4.7
L-1640	18	100	26	20	400	160	5.9

Made of hot-dip galvanized steel.

## 39. Yoke Plate (Type L)

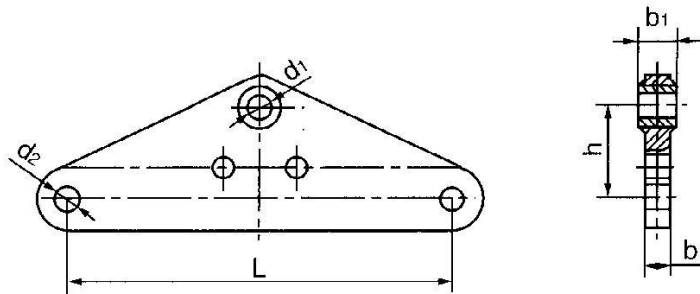

Cat No	Dimensions(mm)						Rated Failure Load (KN)	Weight (Kg)
	b1	b	h	d1	d2	L		
L-2040	26	16	100	30	20	400	200	7.0
L-2540	30	16	110	33	24	400	250	9.0
L-25457	30	16	110	33	24	457	250	10.0
L-3040	32	18	110	39	26	400	300	10.0
L-30457	32	18	110	39	26	457	300	11.2
L-5045	38	32	200	45	39	450	500	25.0
L-50457	38	32	200	45	39	457	500	26.0
L-6045	42	32	200	51	39	450	600	28.0

Made of hot-dip galvanized steel.

## 40. Yoke Plate (Type LF)

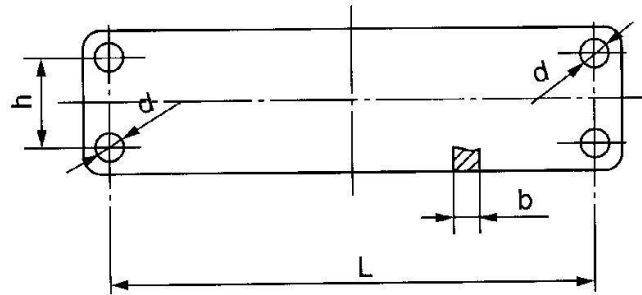

Cat No	Dimensions(mm)				Rated Failure Load (KN)	Weight (Kg)
	b	h	d	L		
LF-2040	16	70	20	400	200	5.5
LF-2540	16	110	24	400	250	9.2
LF-3040	18	120	26	400	300	11.2
LF-3045	18	100	26	450	300	12.0
LF-3050	18	140	26	500	300	16.5

Made of hot-dip galvanized steel.

## 41. Yoke Plate (Type LJ)

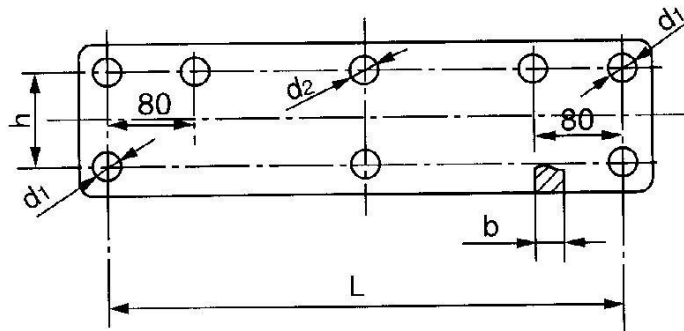

Cat No	Dimensions(mm)					Rated Failure Load (KN)	Weight (Kg)
	b	h	d1	d2	L		
LJ-1040	16	70	18	20	400	100	6.5
LJ-1240	16	70	18	24	400	120	7.0
LJ-1640	18	100	20	26	400	160	9.5

Made of hot-dip galvanized steel.

## 42. Yoke Plate (Type LK)

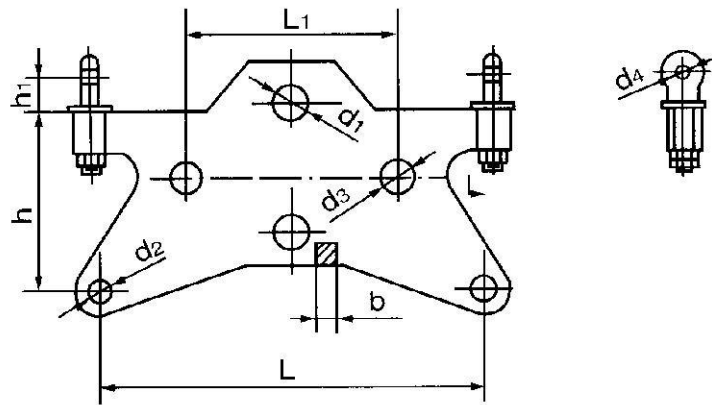

Catalog No.	Dimensions (mm)									Rated Failure Load (KN)	Weight (Kg)
	b	h	h <sub>1</sub>	L	L <sub>1</sub>	d <sub>1</sub>	d <sub>2</sub>	d <sub>3</sub>	d <sub>4</sub>		
LK-0745	18	225	40	450	240	18	18	26	18	70	15.5
LK-1045	16	230	40	450	240	20	18	26	18	100	16.0
LK-1645	18	230	40	450	240	26	18	26	18	160	17.0

Made of hot-dip galvanized steel.

## 43. Yoke Plate (Type LX)

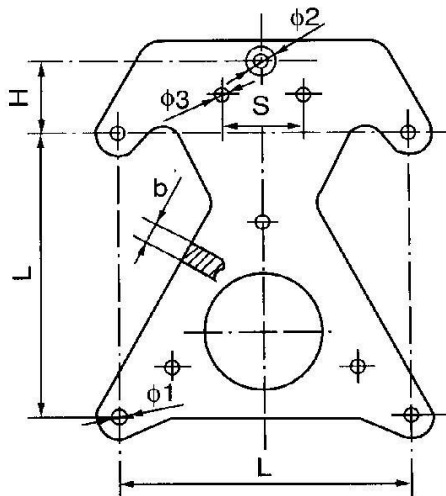

Catalog No.	Dimensions (mm)							Rated Failure Load (KN)	Weight (Kg)
	L	H	φ <sub>1</sub>	φ <sub>2</sub>	φ <sub>3</sub>	b	s		
LX-1645	450	95	20	26	14	18	80	160	26.0
LX-1645A	450	95	20	26	14	18	60	160	26.0
LX-2045A	450	95	20	33	18	18	80	250	29.0

Made of hot-dip galvanized steel.

## 44. Yoke Plate (Type LN)

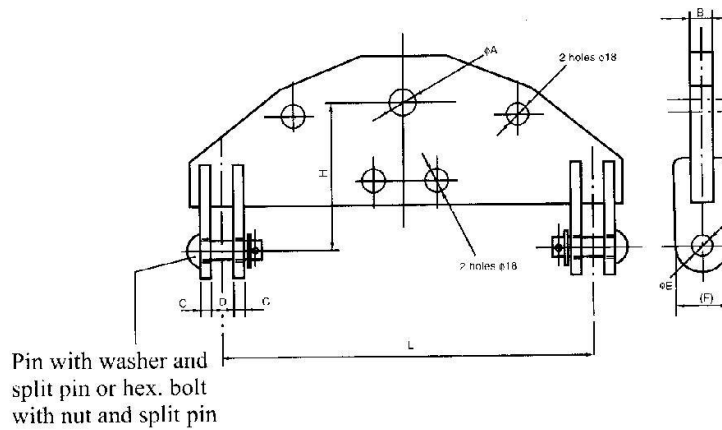

Catalog No.	Dimensions (mm)								Rated Failure Load (KN)	Weight (Kg)
	φA	B	C	D	φE	F	L	H		
LN-1230	24	16	8	24	24	60	300	140	120	6.6
LN-1233	24	16	8	24	24	60	330	140	120	7.3
LN-2030	30	26	12	24	24	72	300	155	190	11.8
LN-2033	30	26	12	30	30	72	330	155	190	13.0
LN-2040	30	26	12	30	30	72	400	155	190	15.7

Made of hot-dip galvanized steel.

## 45. Double Yoke Plates

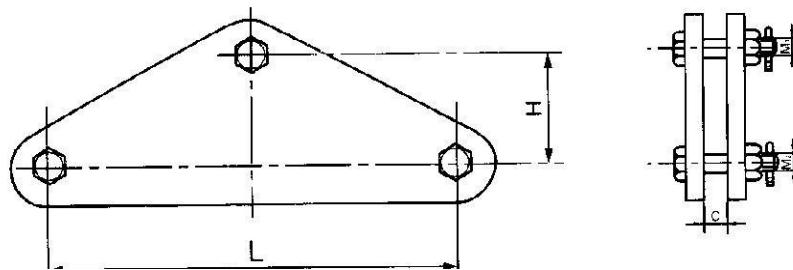

Catalog No.	Dimensions (mm)					Rated Failure Load (KN)	Weight (Kg)
	L	H	C	M <sub>1</sub>	M <sub>2</sub>		
L-1240S	400	180	18	20	16	133	6.0
L-1640S	400	100	22	24	16	160	7.3
L-2040S	400	110	26	27	18	200	8.9
L-12457S	457	80	18	20	16	133	6.4
L-16457S	457	100	22	24	16	160	7.6
L-20457S	457	110	26	27	18	200	9.4

Made of hot-dip galvanized steel.

## 46. Turnbuckle (Type LH2)

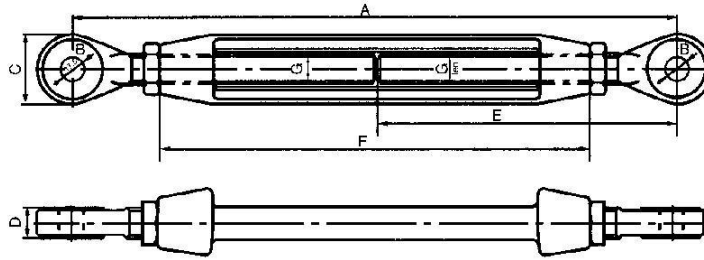

Catalog No.	Dimensions (mm)							Rated Failure Load (KN)	Weight (Kg)
	A	B	C	D	E	F	G		
LH2-7B	400~600	17.5	42	16	197	260	20	70	2.5
LH2-7BU	400~600	17.5	42	16	197	260	20	70	2.5
LH2-7U	400~600	17.5	42	16	197	260	20	70	2.5
LH2-12B	440~430	21.5	46	18	215	290	24	120	3.6
LH2-12BU	440~630	21.5	46	18	215	290	24	120	3.6
LH2-12U	440~630	21.5	46	18	215	290	24	120	3.6
LH2-16B	590~890	25.5	54	20	290	380	27	160	6.9
LH2-16BU	590~890	25.5	54	20	290	380	27	160	6.9
LH2-16U	590~890	25.5	54	20	290	380	27	160	6.9

Made of hot-dip galvanized steel.

## 47. Turnbuckle (Type LH)

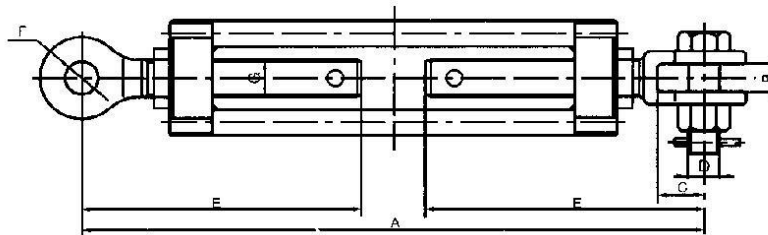

Catalog No.	Dimensions (mm)							Rated Failure Load (KN)	Weight (Kg)
	A	B	C	D	E	F	G		
LH-7BU	350~500	20	32	16	170	18	20	70	2.1
LH-12BU	400~550	24	46	20	195	22	24	120	2.8
LH-16BU	500~650	30	54	24	245	26	27	160	6.5

Made of hot-dip galvanized steel.